

BEGA**84 075**

Garden luminaire



Project · Reference number



Date

Product data sheet

Application

Shielded garden luminaire with directed light. A shield made of aluminium screens the light of the luminaire upwards and forwards and directs it onto the surface to be illuminated. A small light aperture on the back illuminates additionally the luminaire shape. For illumination of paths, beds and terraces in private applications.

Product description

Luminaire made of aluminium profile, aluminium alloy, aluminium and stainless steel
 BEGA Unidure® coating technology
 Antique glass
 Silicone gasket
 Luminaire with mounting plate for bolting onto a foundation or an anchorage unit
 Mounting plate with two pitch circles:
 ø 70 mm, 3 elongated holes 7 mm wide
 ø 100 mm, 3 elongated holes 9 mm wide
 Connection box for through-wiring
 – for 2 cables up to 5 × 2,5²
 with fuse Neozed D 01 · 6 A
 Lampholder E 27
 Safety class I
 Protection class IP 64
 Dust-tight and protection against splash water
 Impact strength IK02
 Protection against mechanical impacts < 0.2 joule
 – Safety mark
 – Conformity mark
 Weight: 6.5 kg

Lamp

Luminaire with screw base E 27
 Lamp output max. 60 W
 This product contains light source of energy efficiency class E

Supplied lamp
 BEGA LED lamp **13584**
 LED Retrofit 7 W · 805 lm · 3000 K

Luminaire efficiency: 10%

Additional BEGA LED lamps are available for this luminaire:

13586 LED 7 W · 805 lm · 3000 K
 dimmable

Detailed technical and lighting data for the lamps can be found in the data sheets on our website.

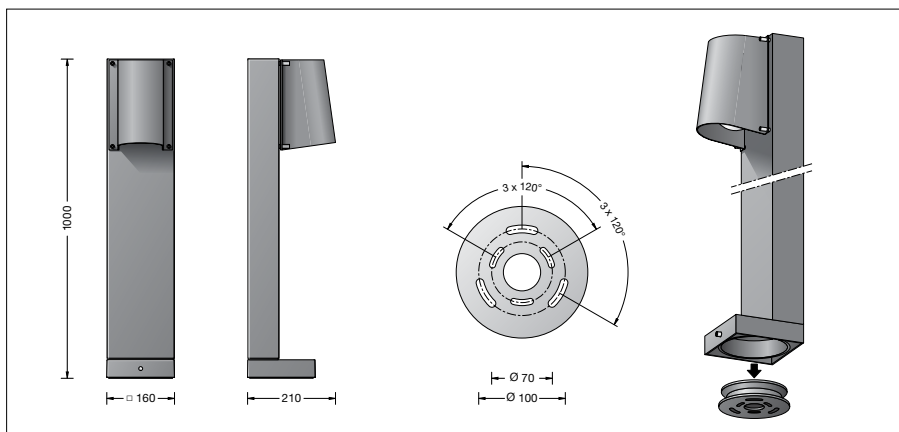

Accessory

70895 Anchorage unit with mounting flange made of hot-dip galvanised steel. Total length 400 mm. 3 stainless steel fixing screws M8. Pitch circle ø 100 mm.

See the separate instructions for use.

Article No. 84 075

Colour graphite or bronze
 graphite – article number
 bronze – article number + **B**